

TECHNOLOGICAL REPORT

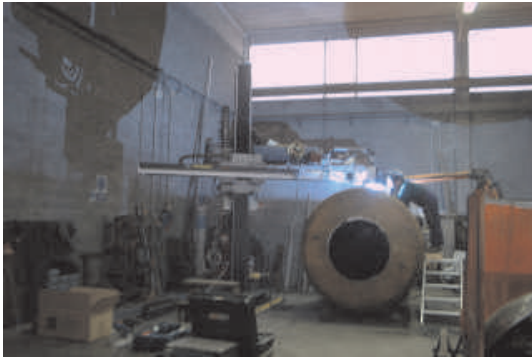

CARPANO
EQUIPMENT



Our work is not just to make standard machines but also a lot of different special machines

In the following pages we try to supply some significant examples of this work

If you have other need please contact us for more info

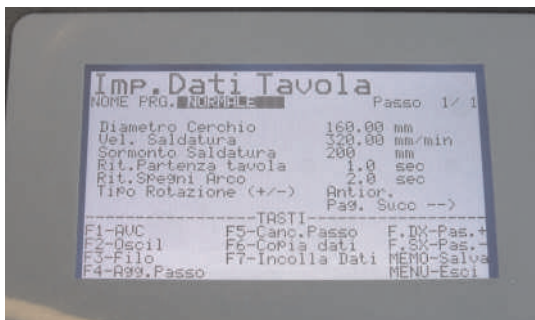

Joda 1 with CNC for step positioning



Joda with 5 axis CNC

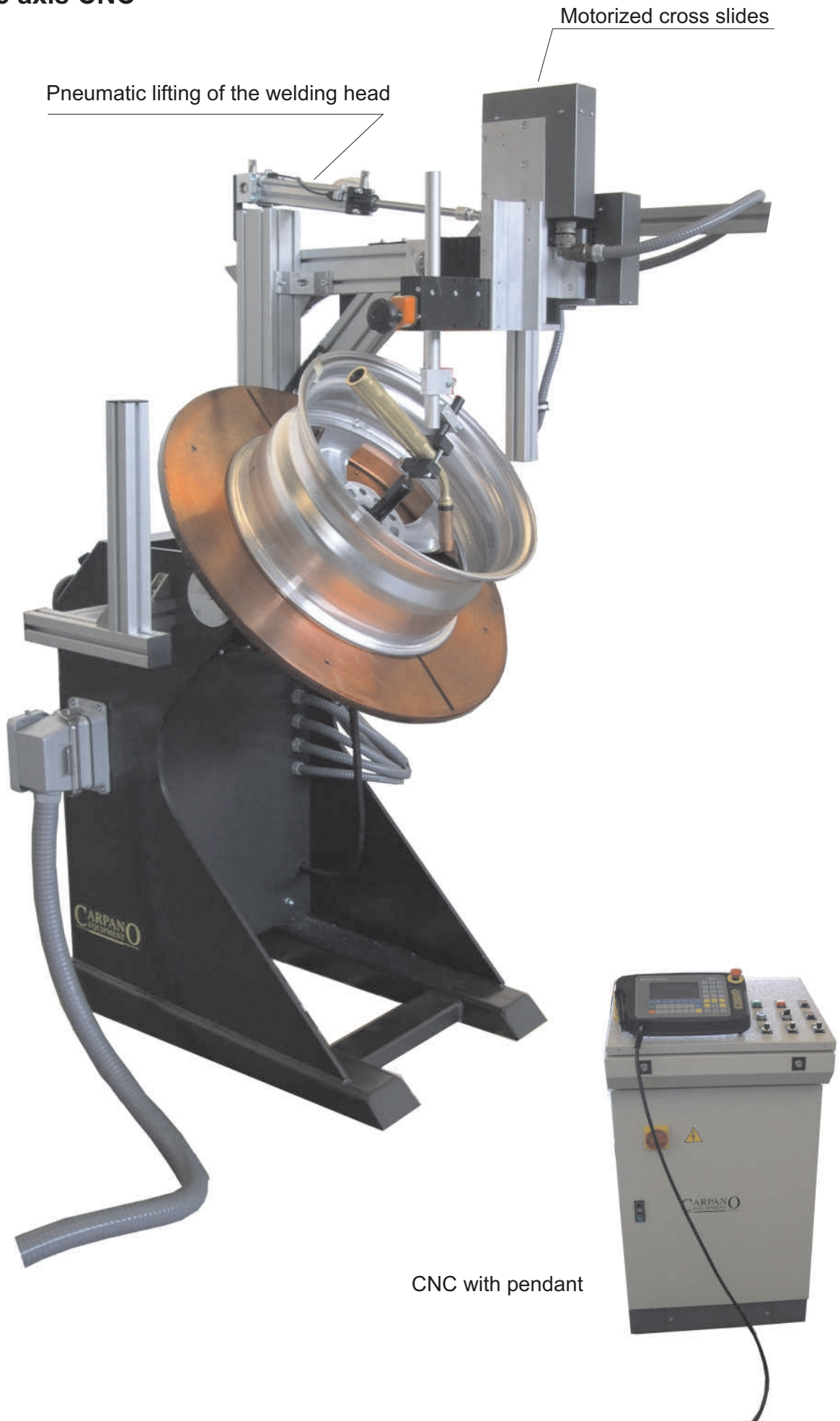

*Automatic machine for pipe Plasma cutting
An Industrial PC with CAD/CAM controls 6 axis to cut the pipe for holes or intersections.*



Machine for wheels welding
 During the welding of 2 wheels the operator can charge or discharge the other 2.

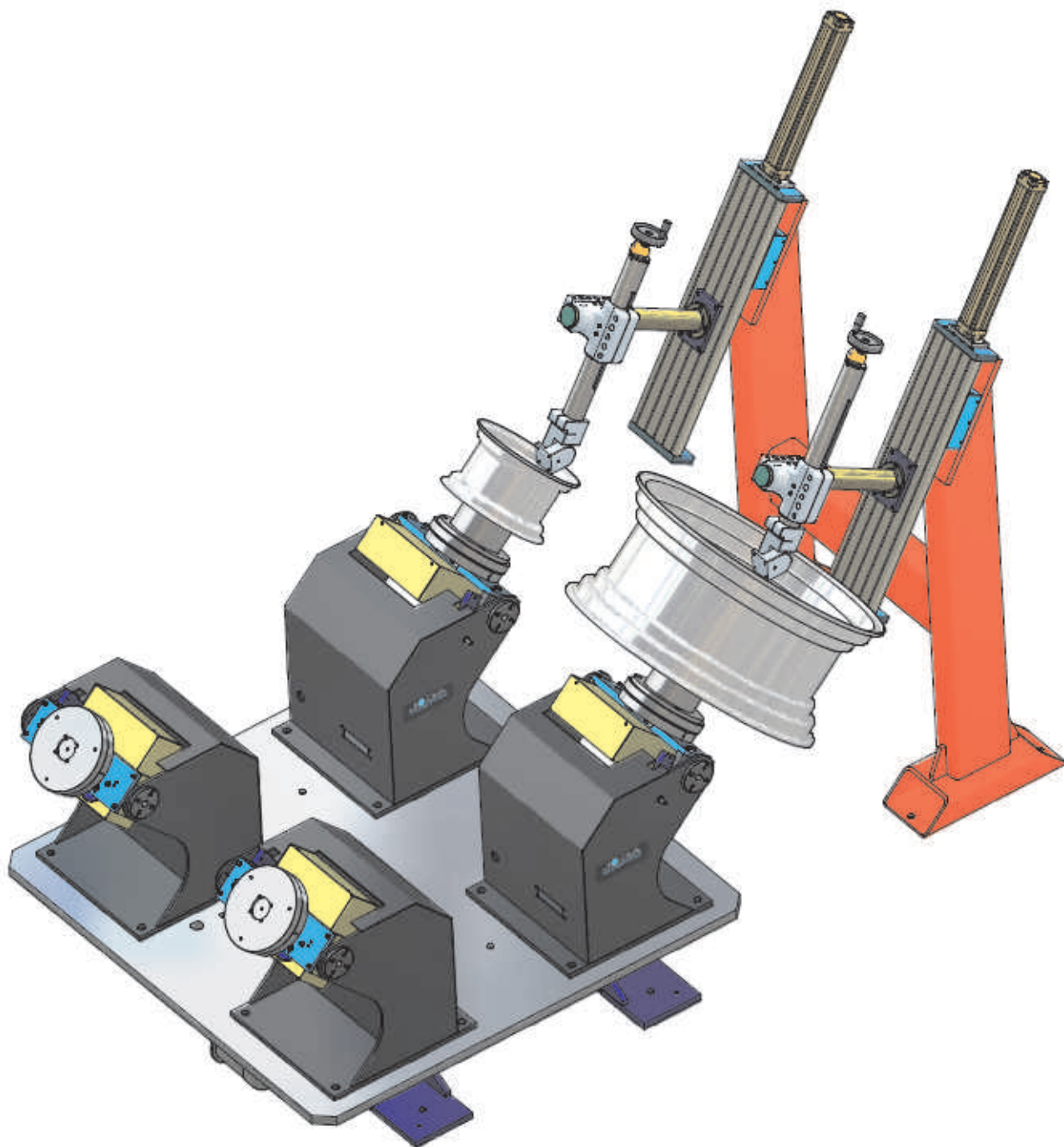

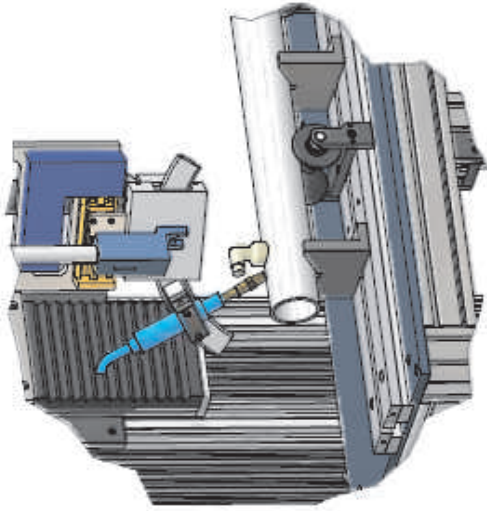
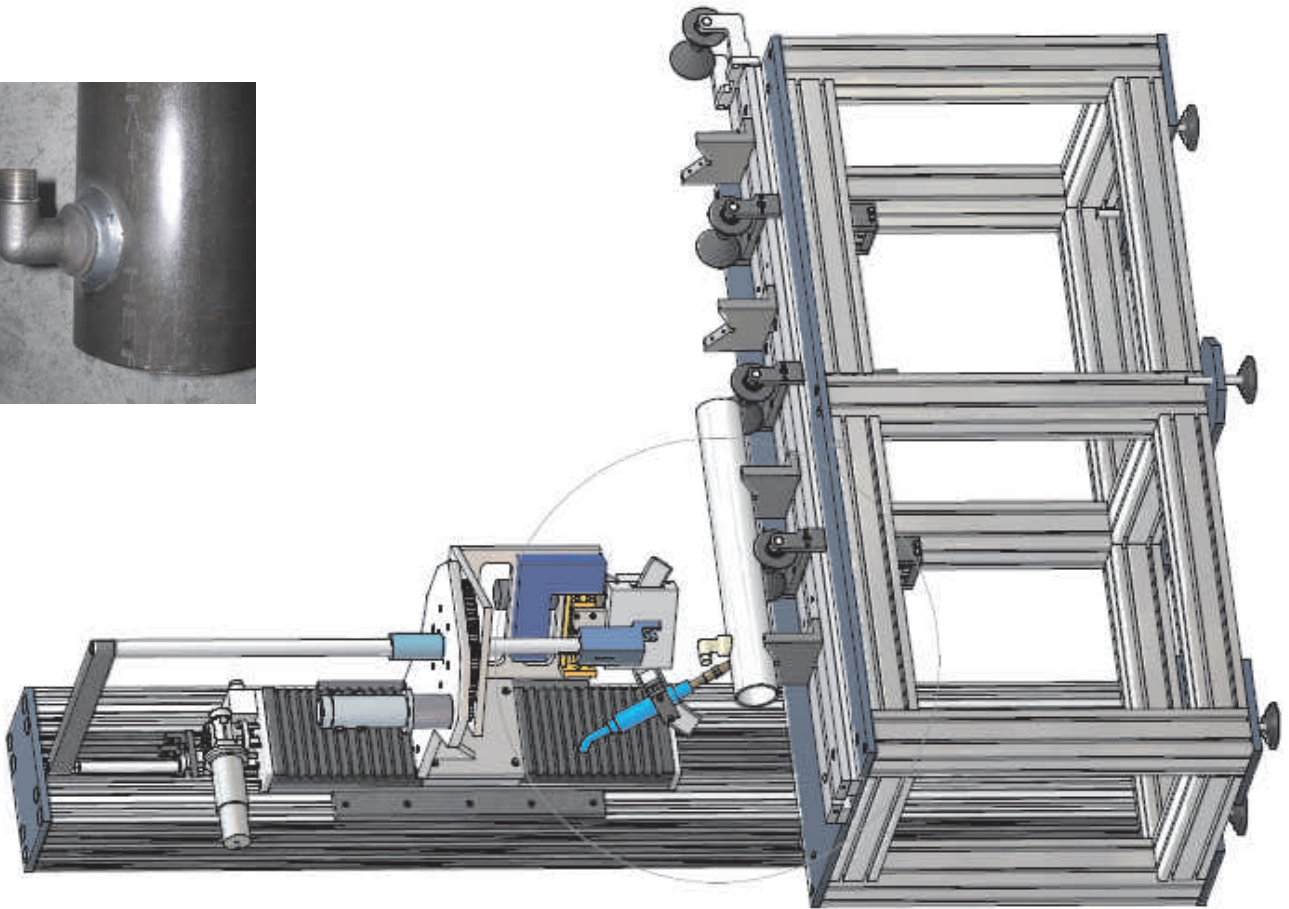

This machine has 4 motorized axis, and 3 are interpolated

the setting of the machine it is very simple:

- Ø of the cylinder
- Ø of the elbow
- welding speed, and overlap
- job of the welding machine

and the CNC will supply the correct movement of the axis

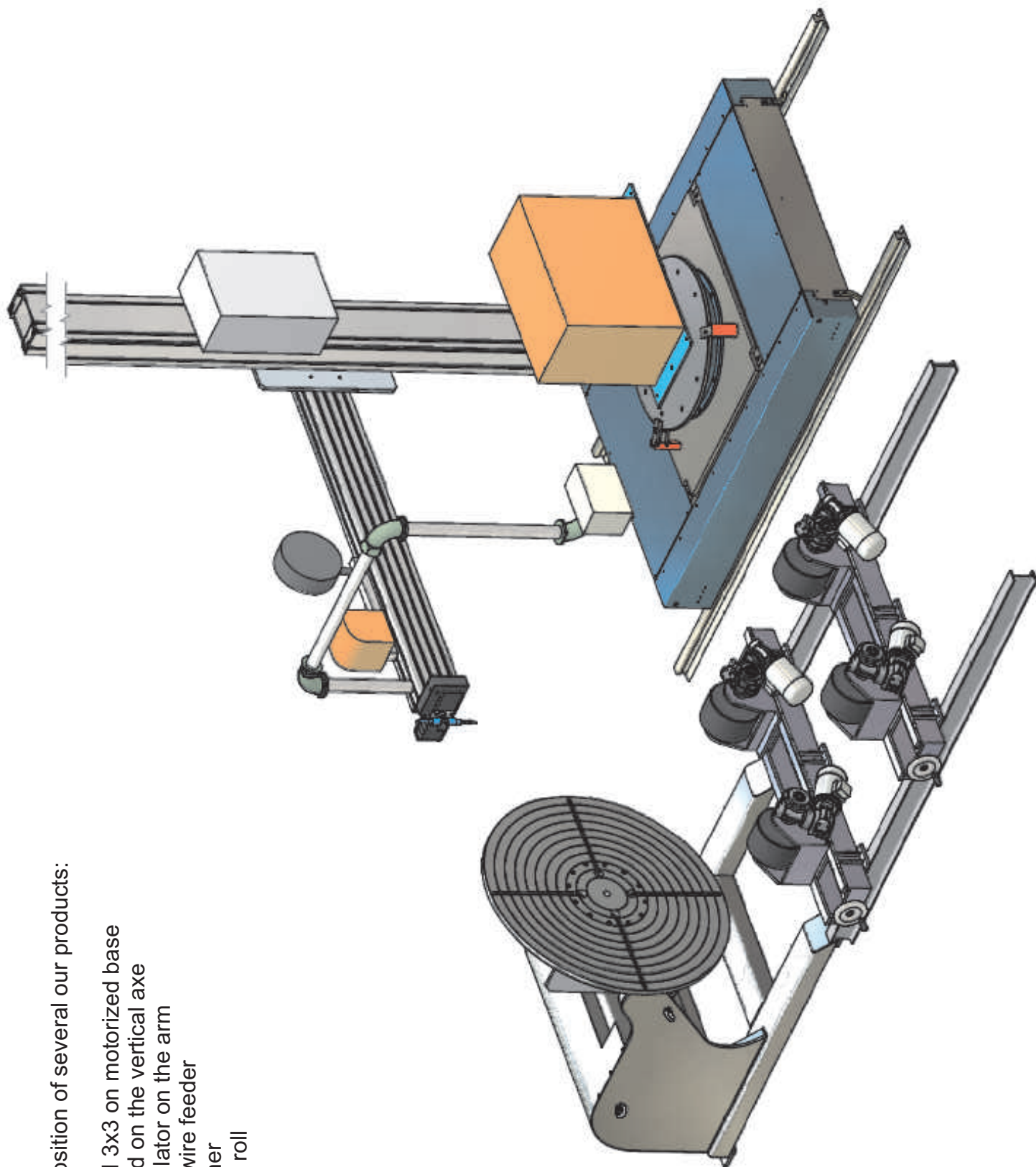

This is a composition of several our products:

- AI Power MIDI 3x3 on motorized base
- AVC integrated on the vertical axis
- DTE 180 oscillator on the arm
- VPR-02 cold wire feeder
- JD 20 positioner
- IPTR5 turning roll

- In this machine the CNC controls:
- Positioner and carriage (with synchronism)
 - Oscillator
 - AVC
 - Welding parameters

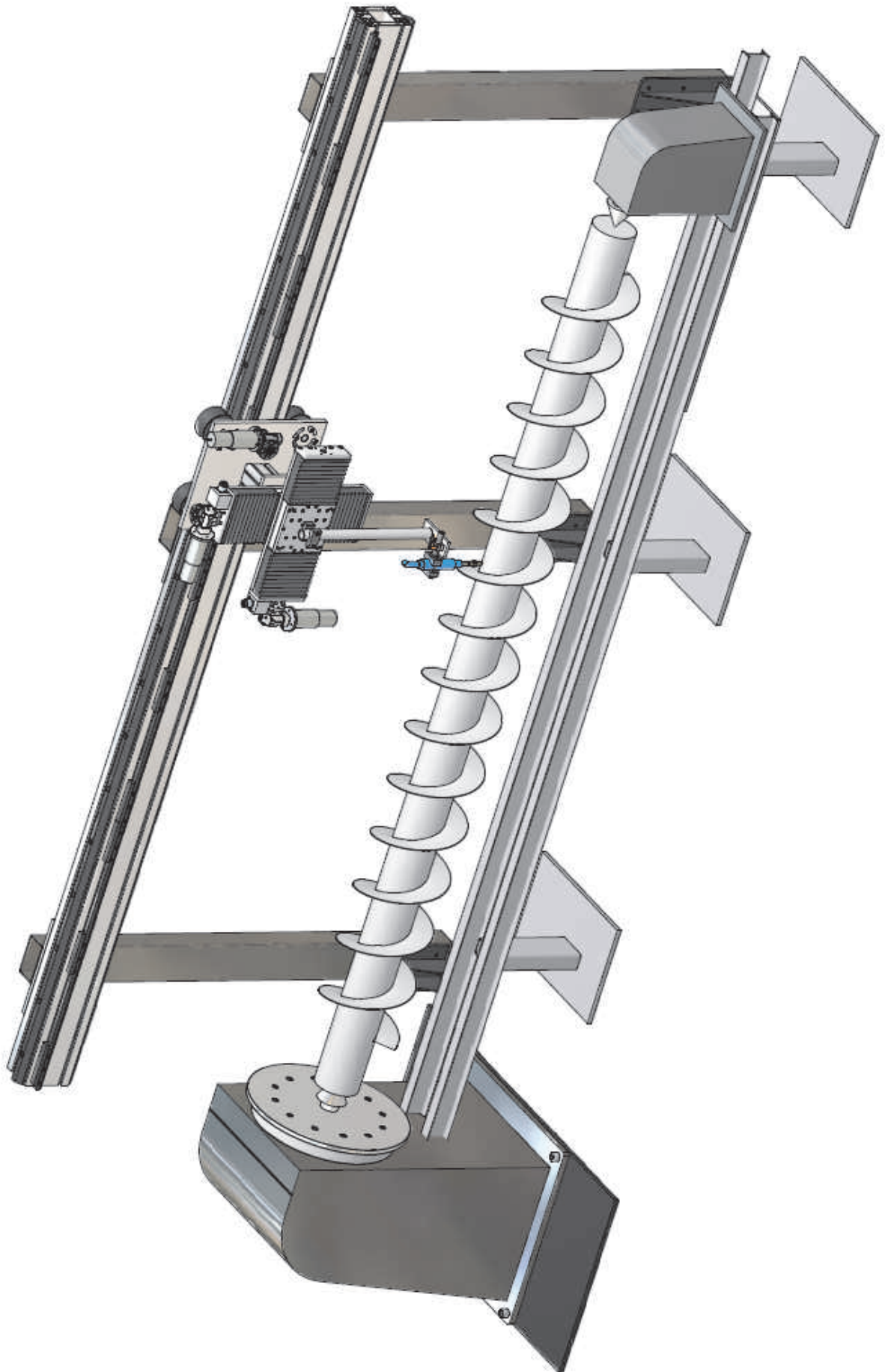

AI Power Micro interpolated with Joda 1, to weld a square tube with a flange

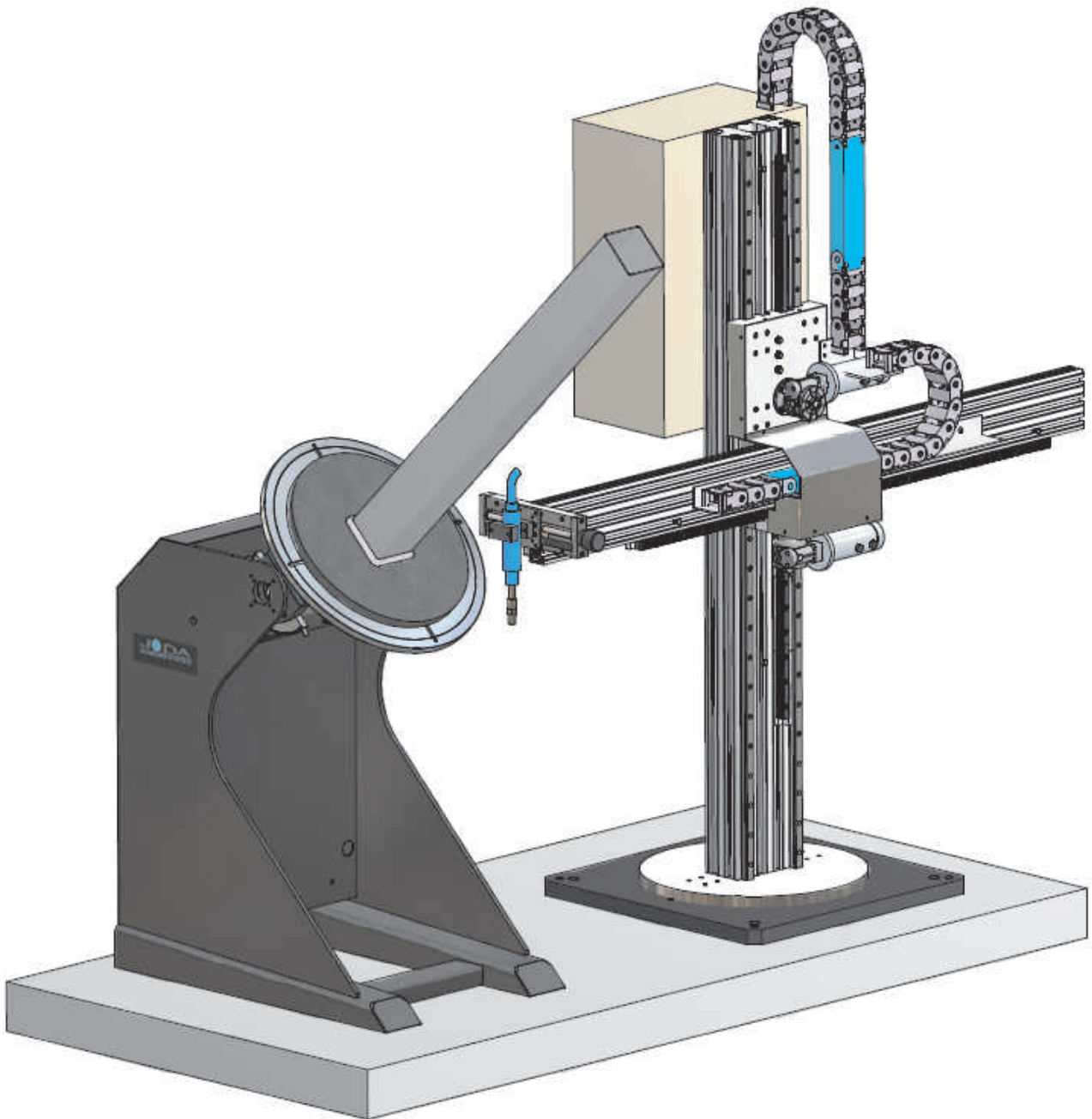

Motorized beam APTM MIDI

Motorized beam with motorized cross slide 600/2 , the vertical slide is fixed on the carriage

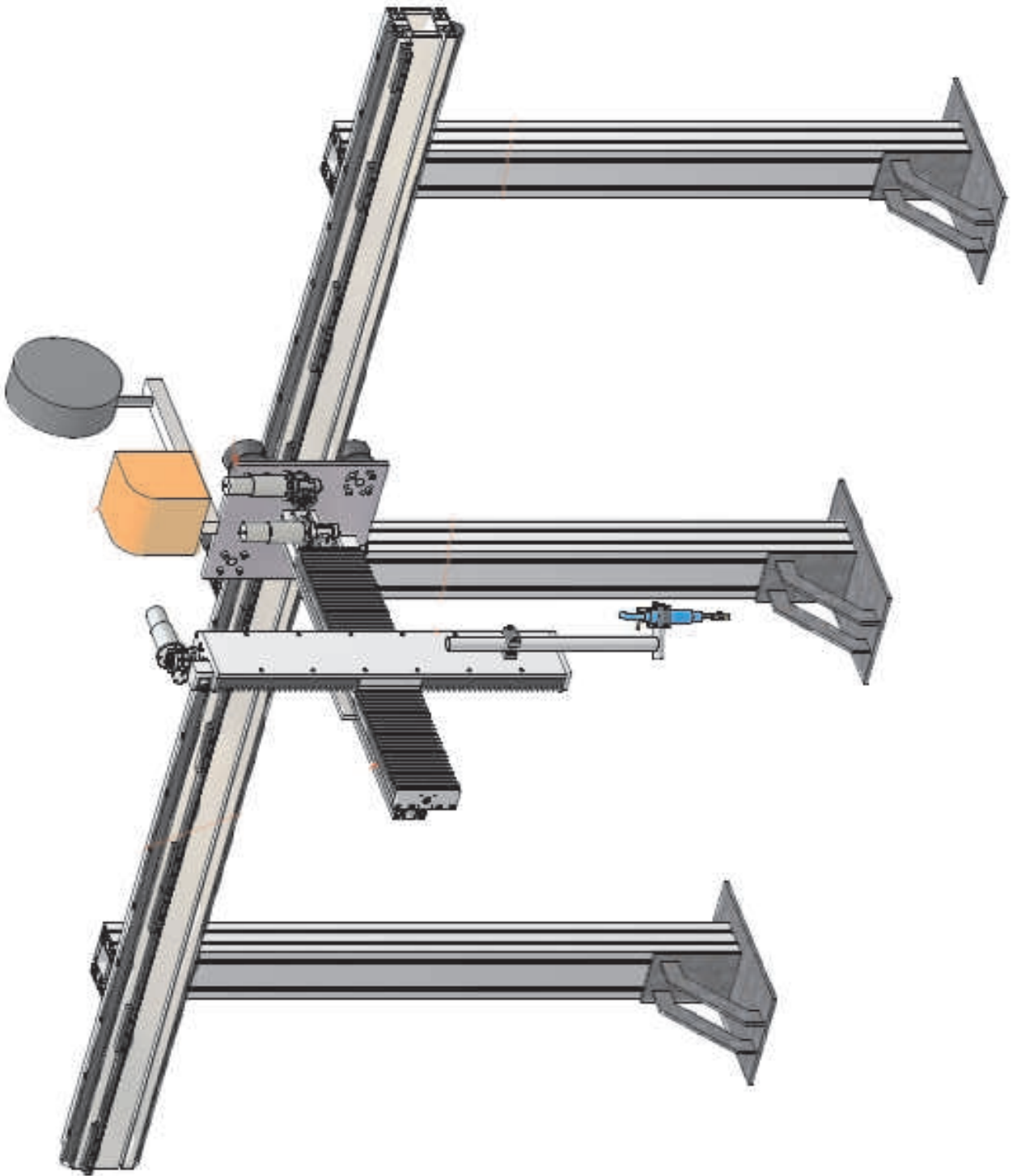

Multipass welding

With the CNC at each rotation the system can change all the parameters of different components

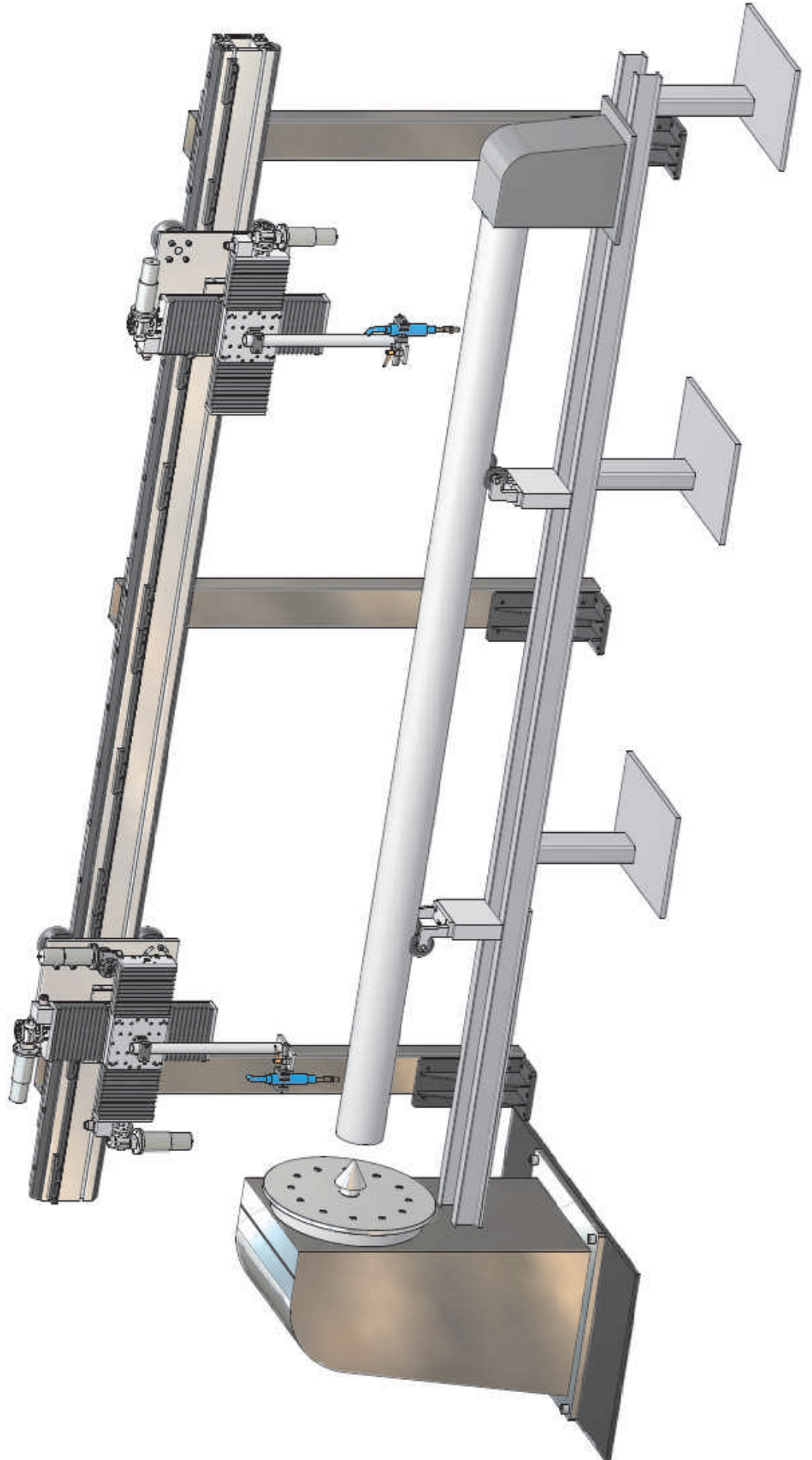

AI Power MINI sliding on a ball bearing track

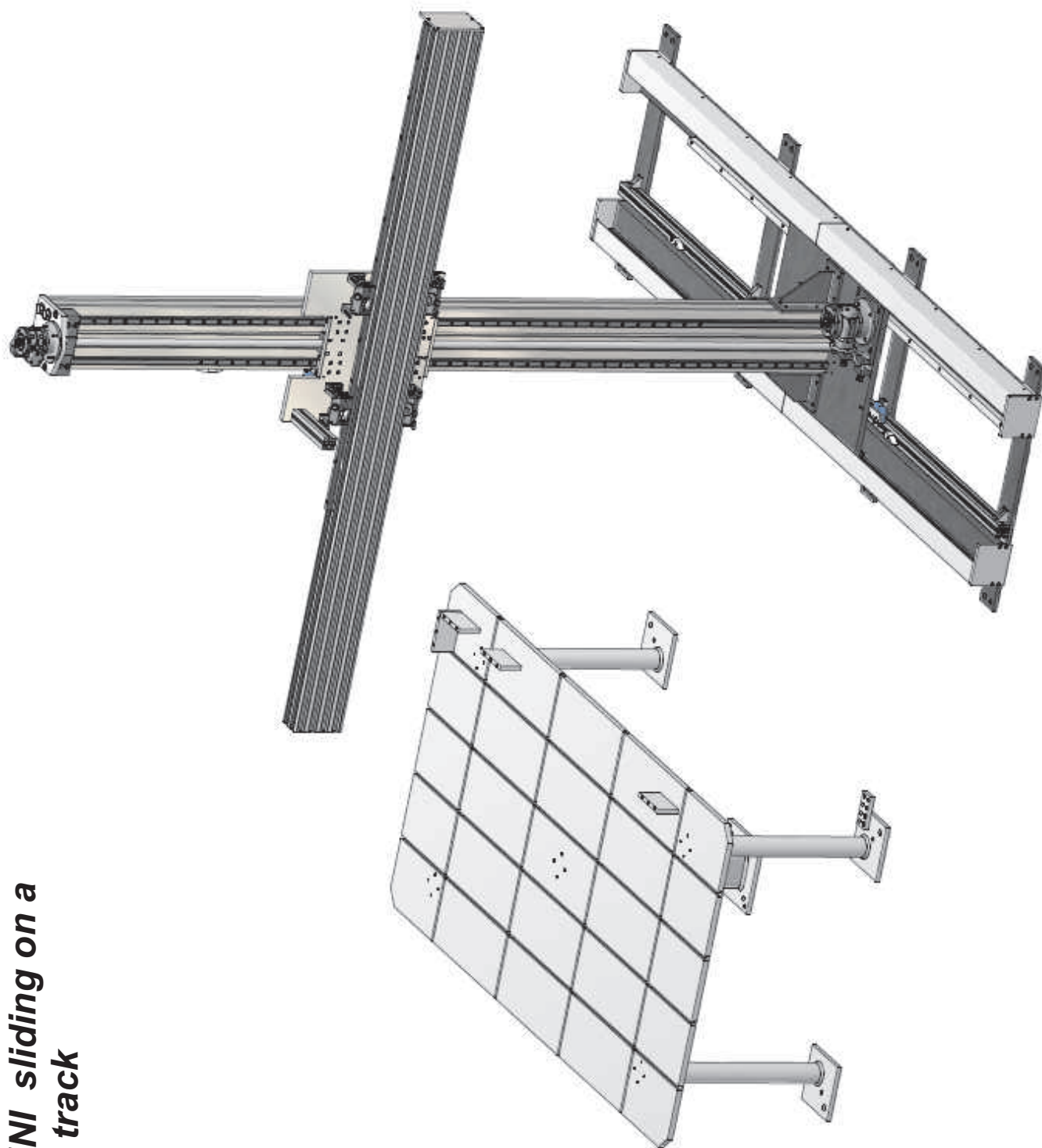

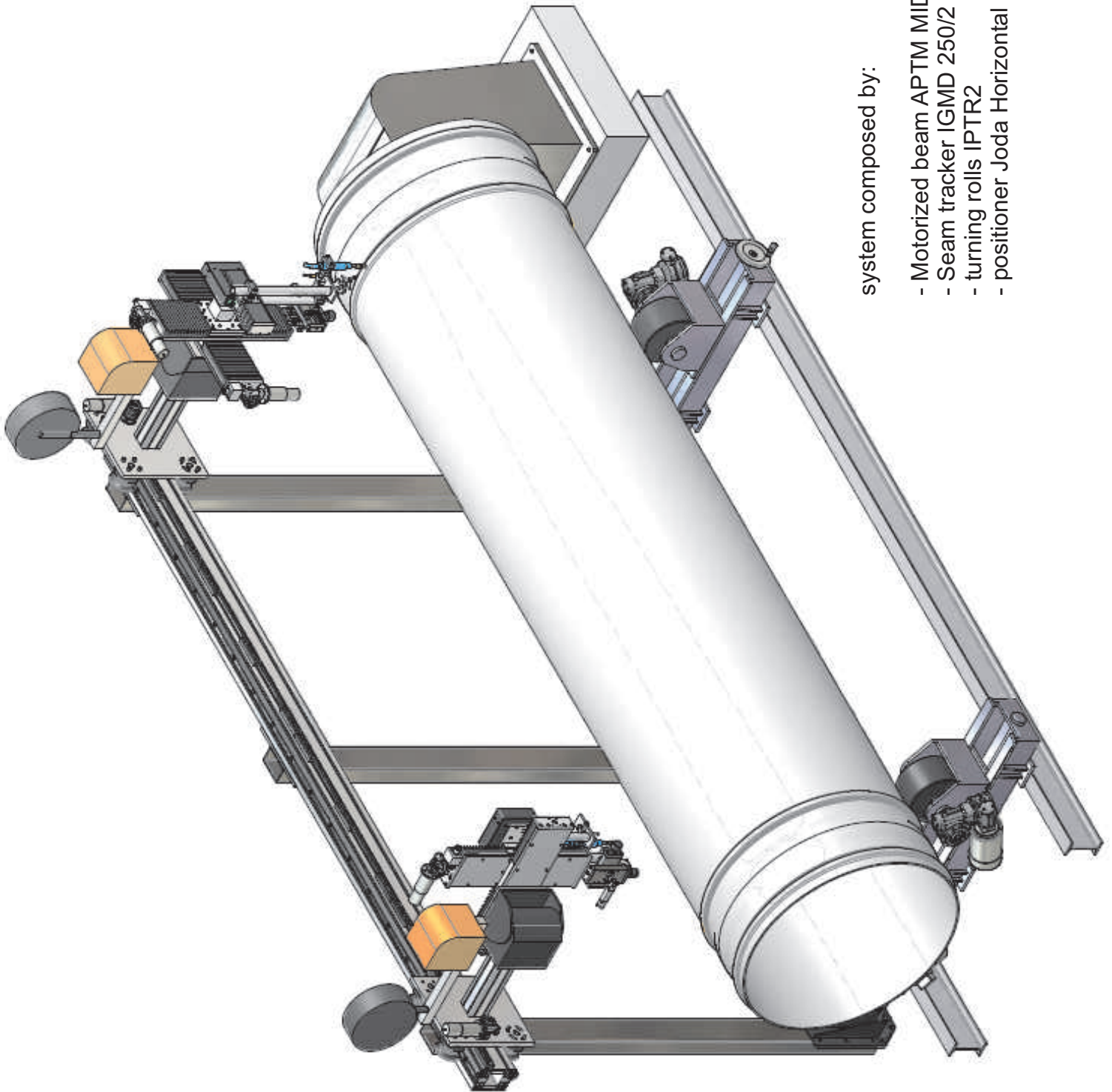

system composed by:

- Motorized beam APTM MIDI
- Seam tracker IGMD 250/2
- turning rolls IPTR2
- positioner Joda Horizontal

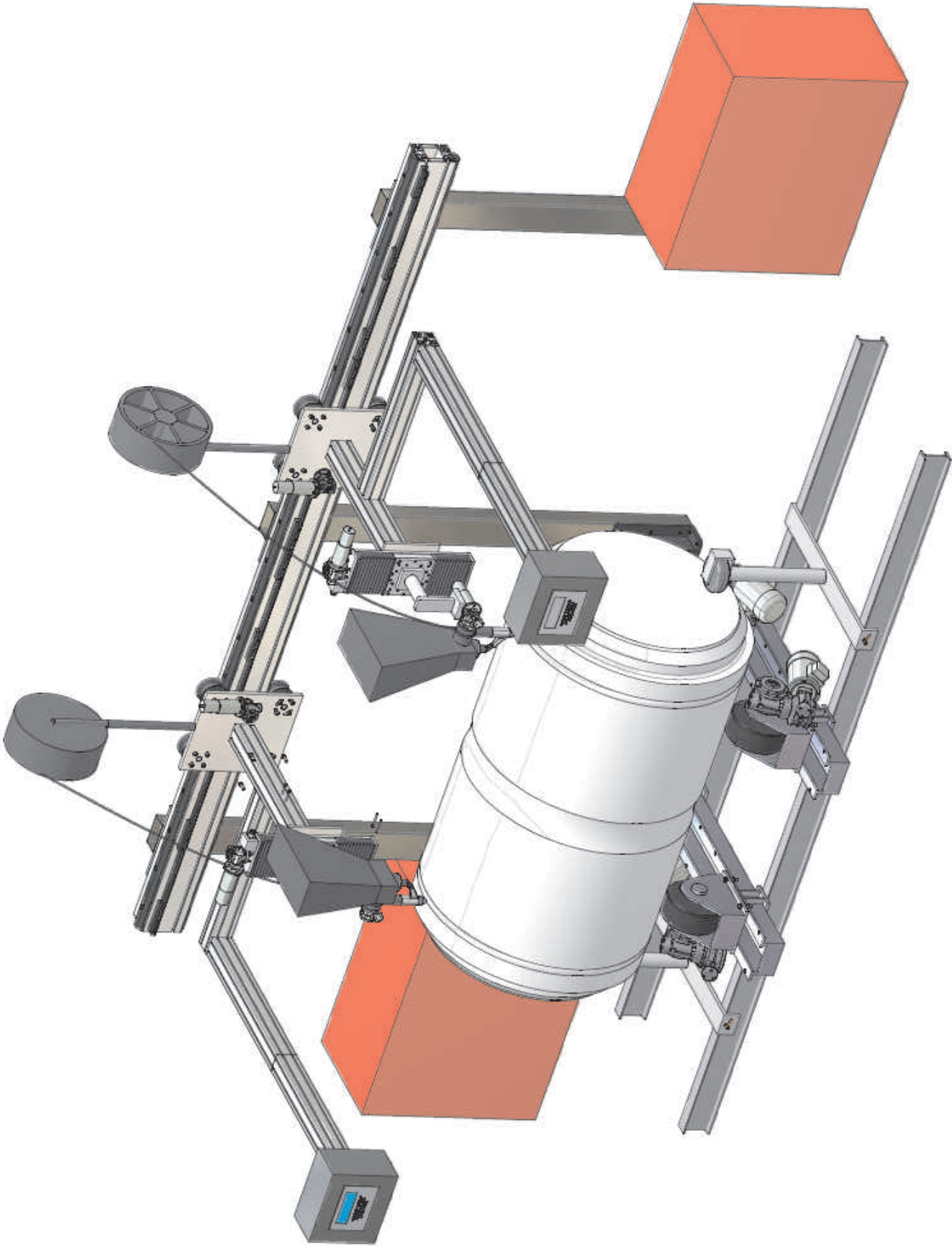

AI Power MICRO and Joda 5

sincronized machine for hard-facing

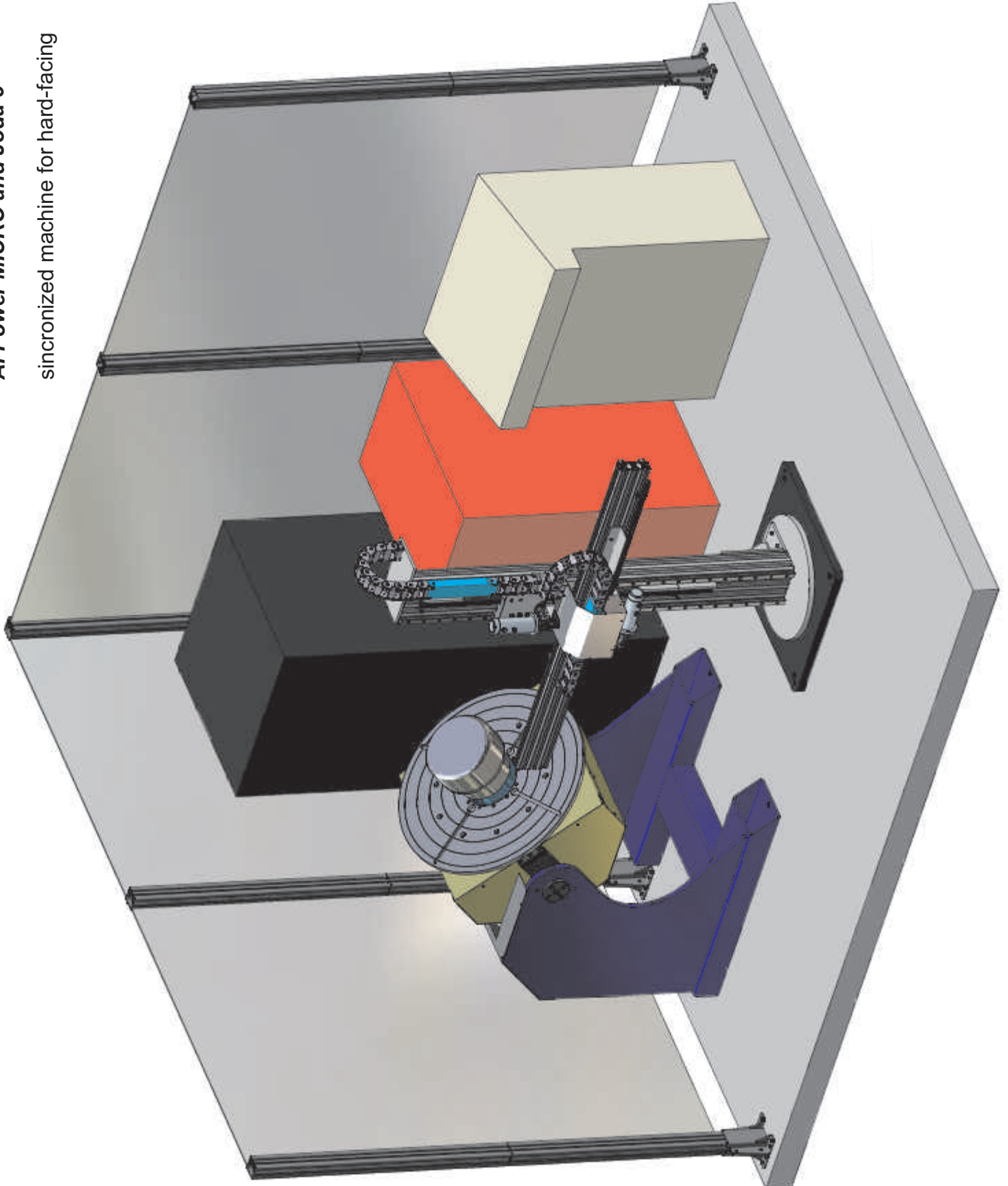

Machine composed by

- Joda Horizontal
- Track for idler positioner
- idler positioner
- APTM MIDI, with motorized carriage
- seam tracker IG MD 600/2
- Dte 180 oscillator
- Electrical box with controller for program the sequence of work

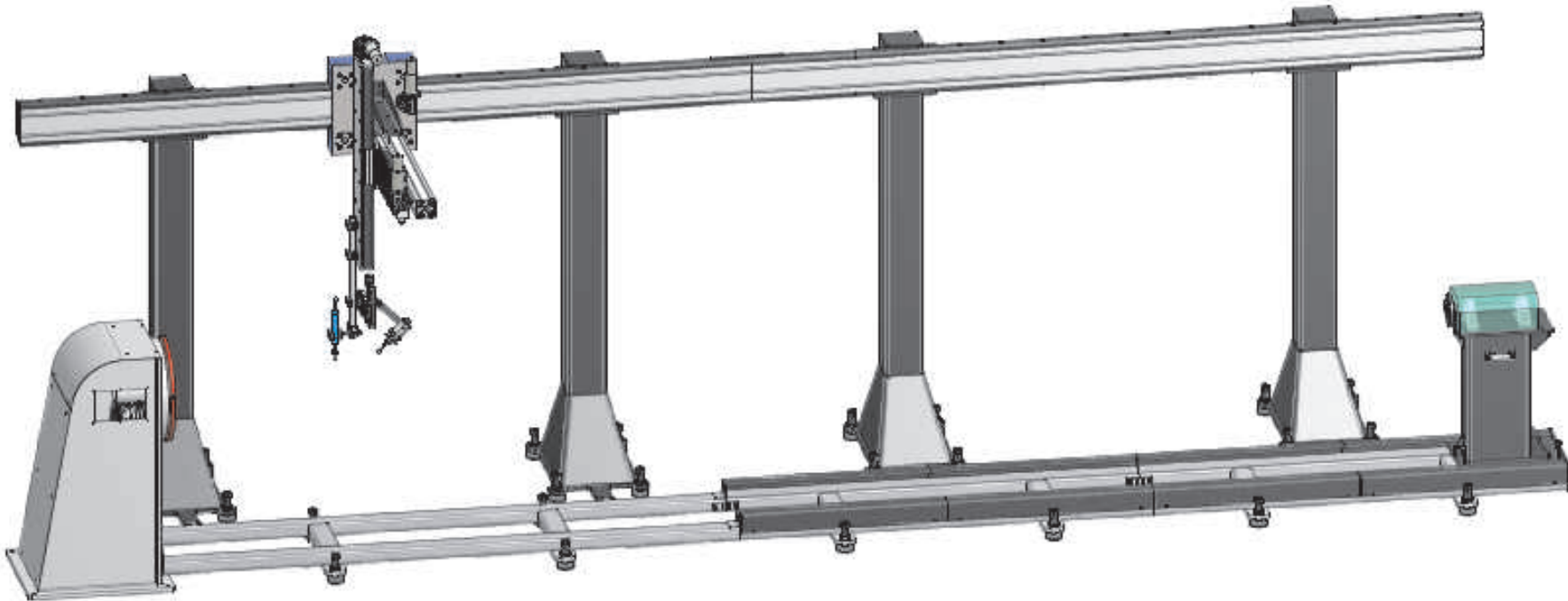

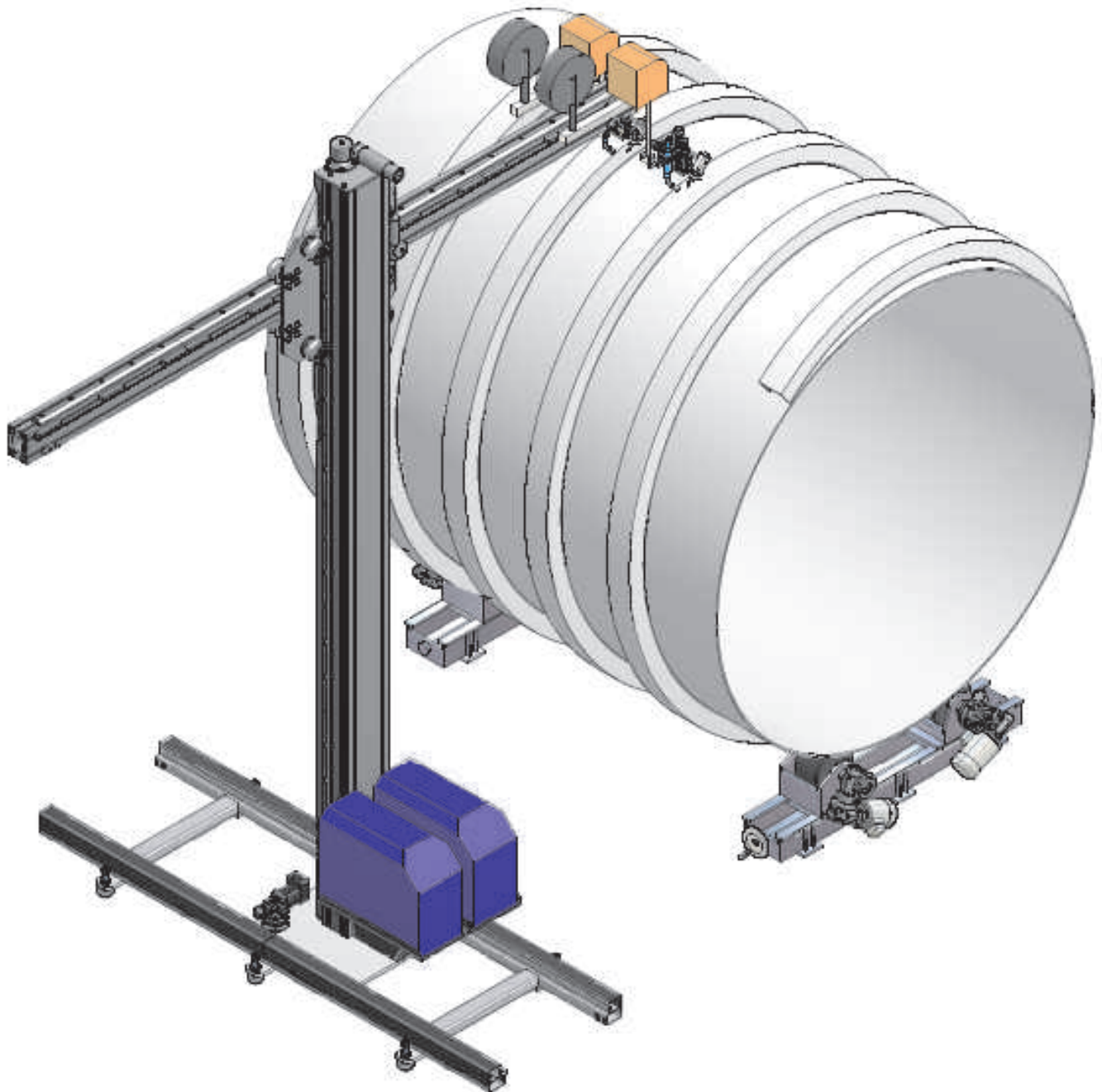

AI Power Midi 3x2 on special track
in this configuration the motorized base and the arm are driven by the seam tracker
on the torch

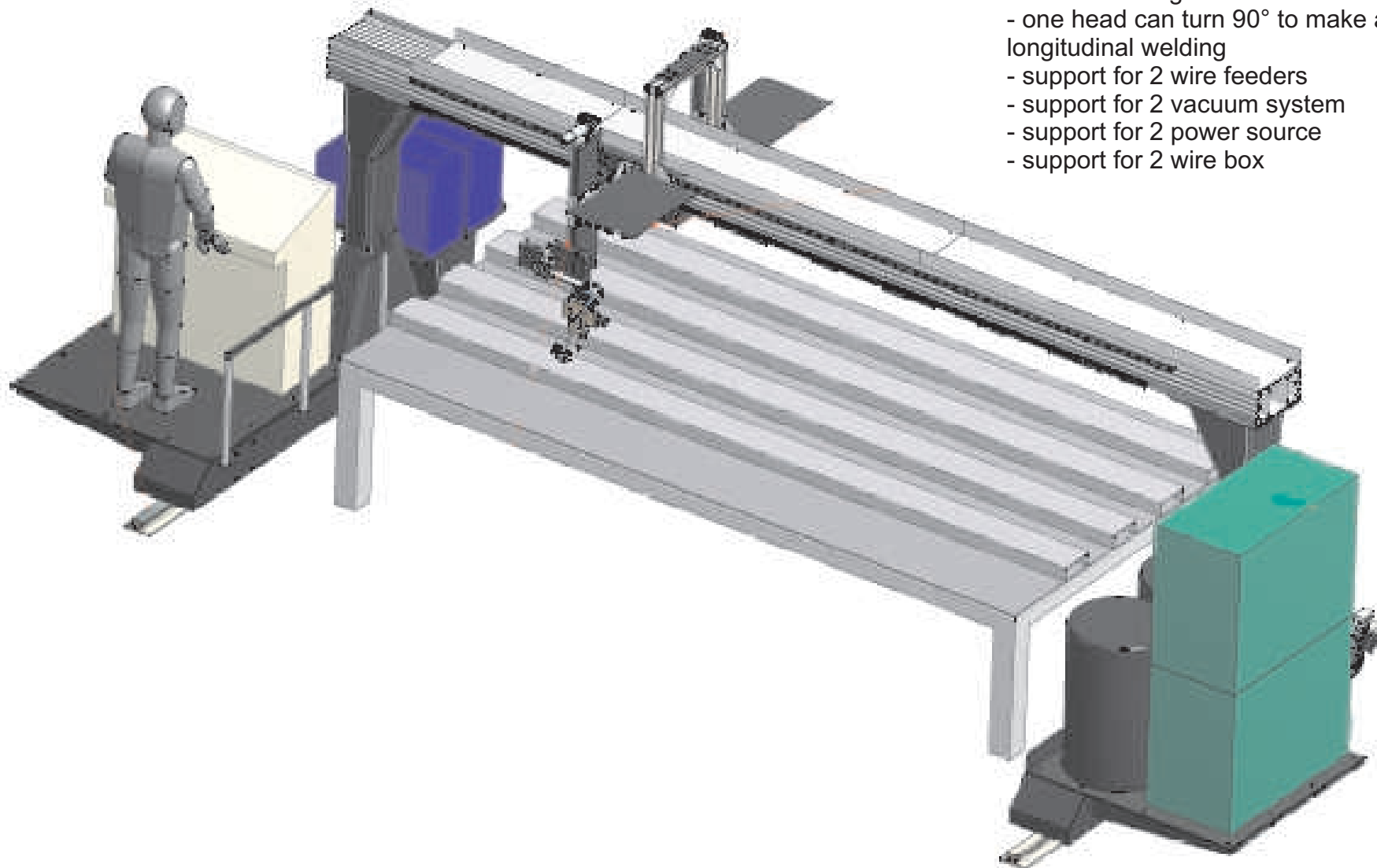

Motorized gantry, with:

- motorized carriage
- 2 MIG welding head with seam tracker
- one head can turn 90° to make also longitudinal welding
- support for 2 wire feeders
- support for 2 vacuum system
- support for 2 power source
- support for 2 wire box

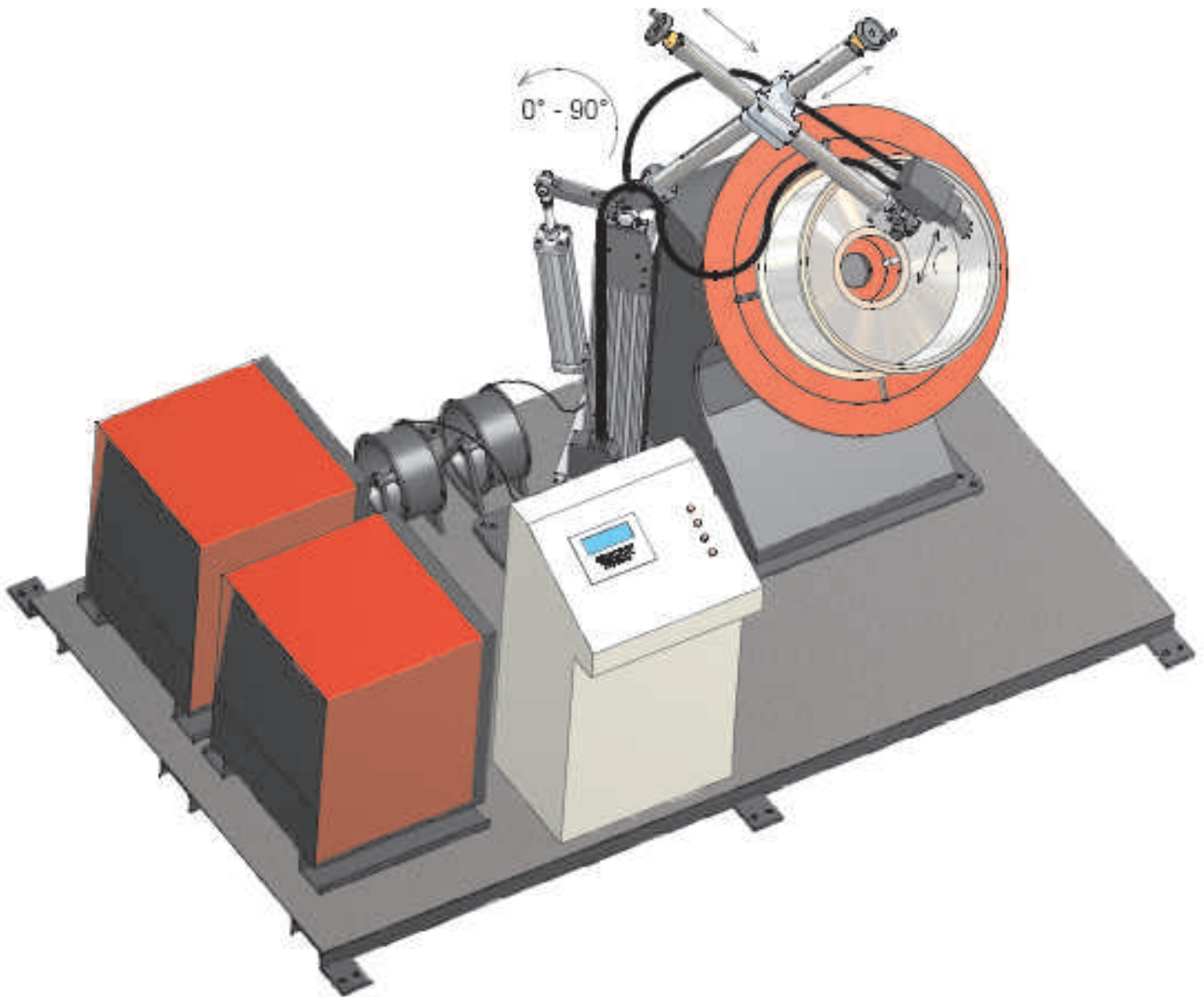

Special positioner with Numeric control to:

- control the tilting position
- rotation
- setting of 2 tandem MIG power source

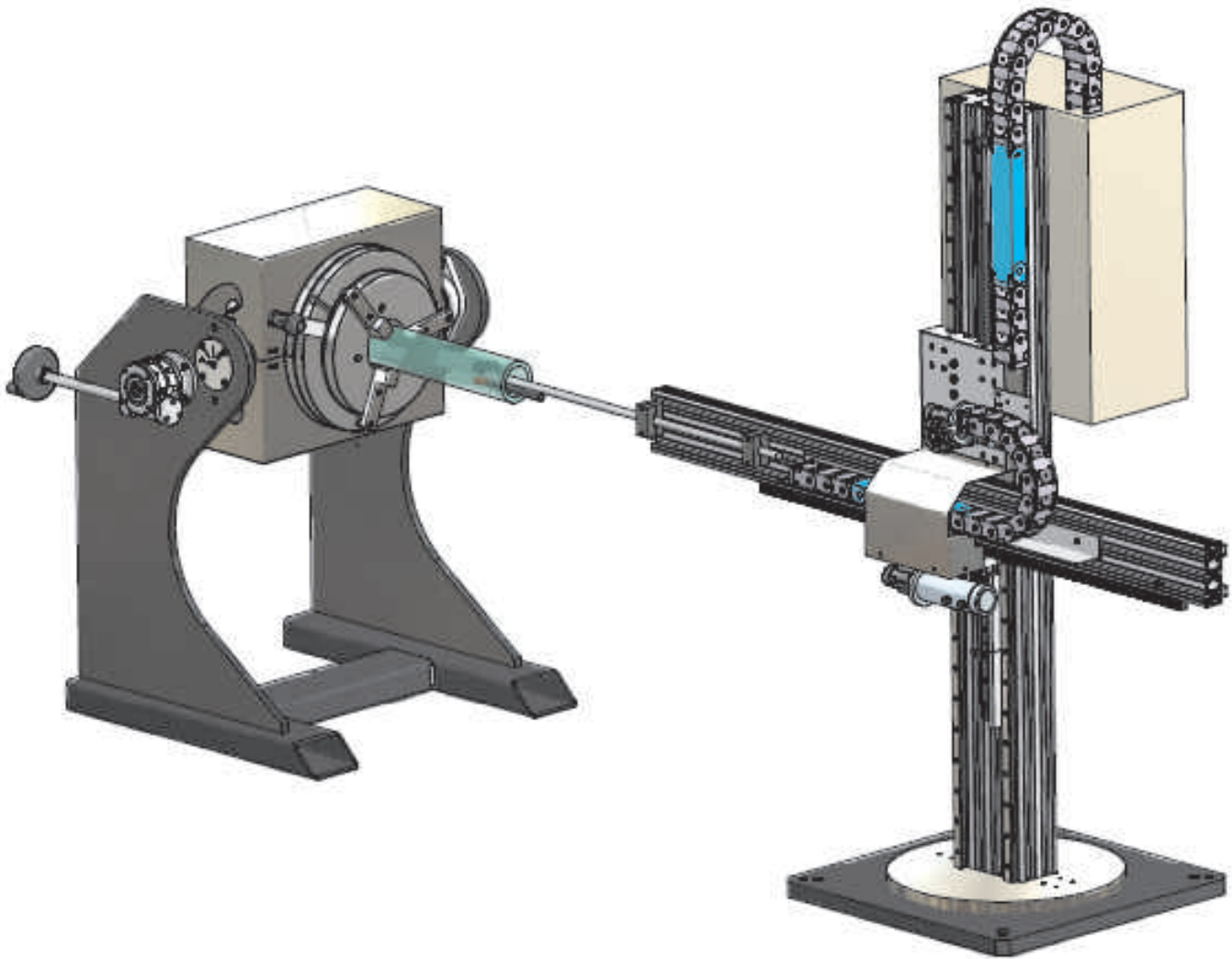

AI Power Micro with Joda 1-100

machine with numeric control, to carry out the cladding inside
a pipe
minimum internal $\text{Ø}40$ mm

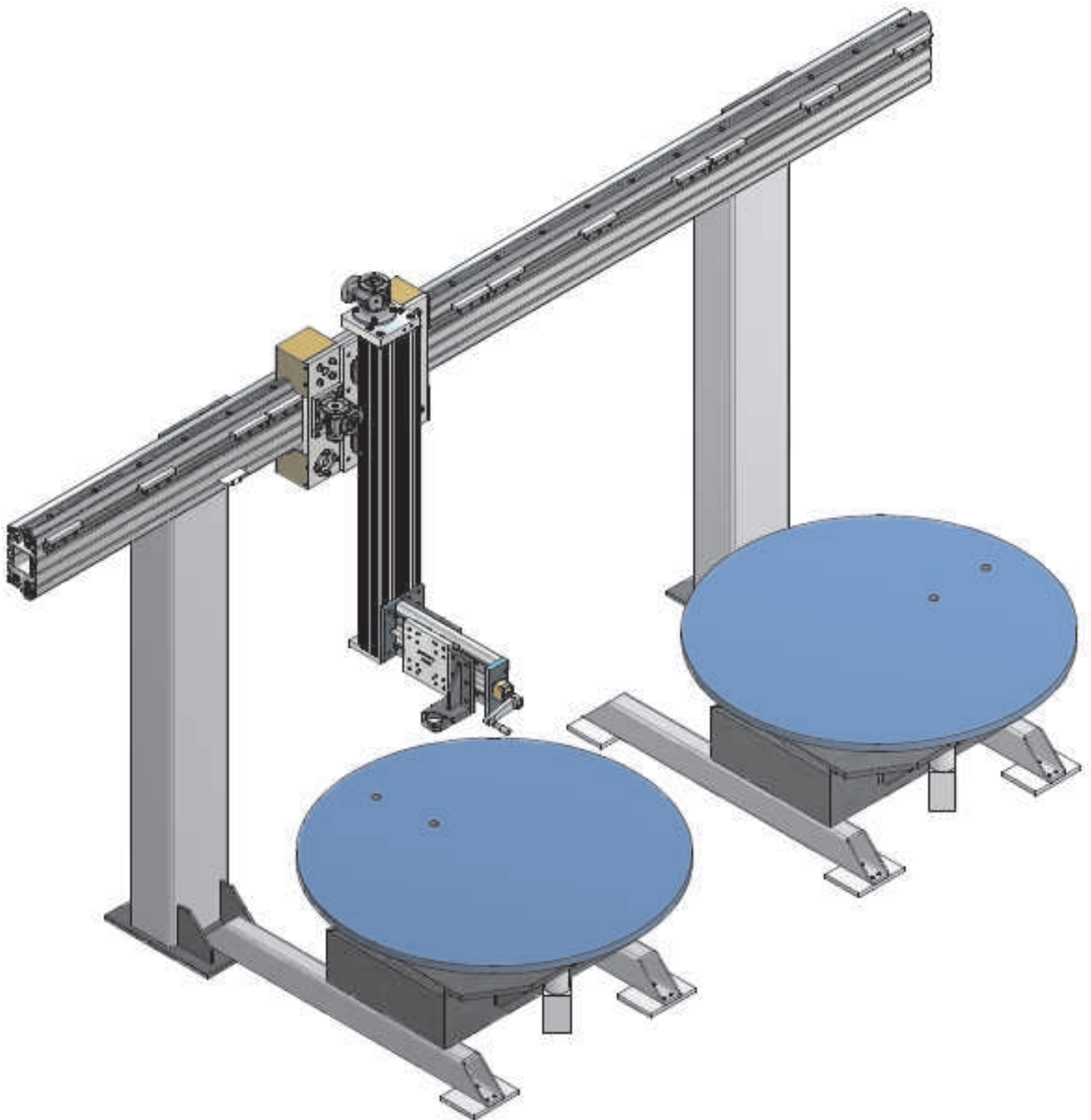

2 Joda Plano with a motorized beam with one vertical motorized axe

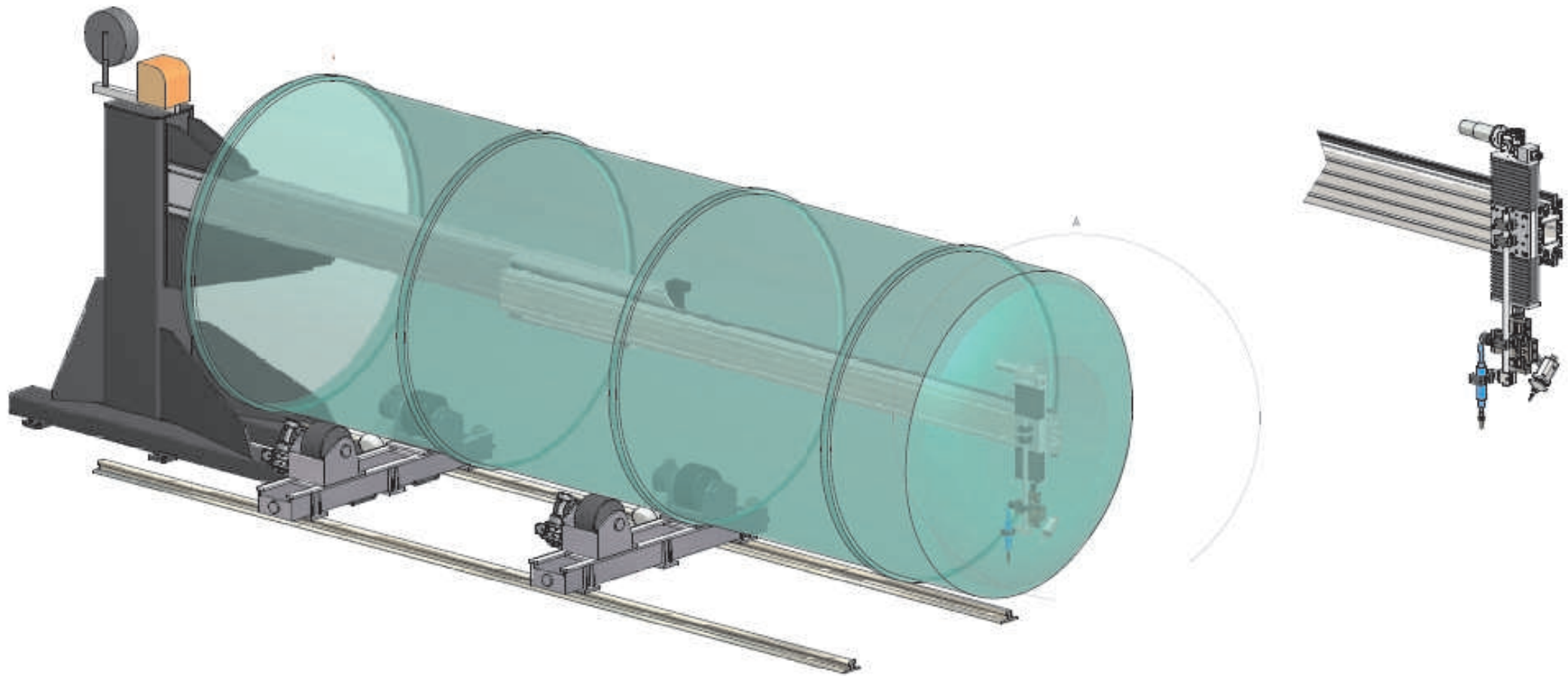

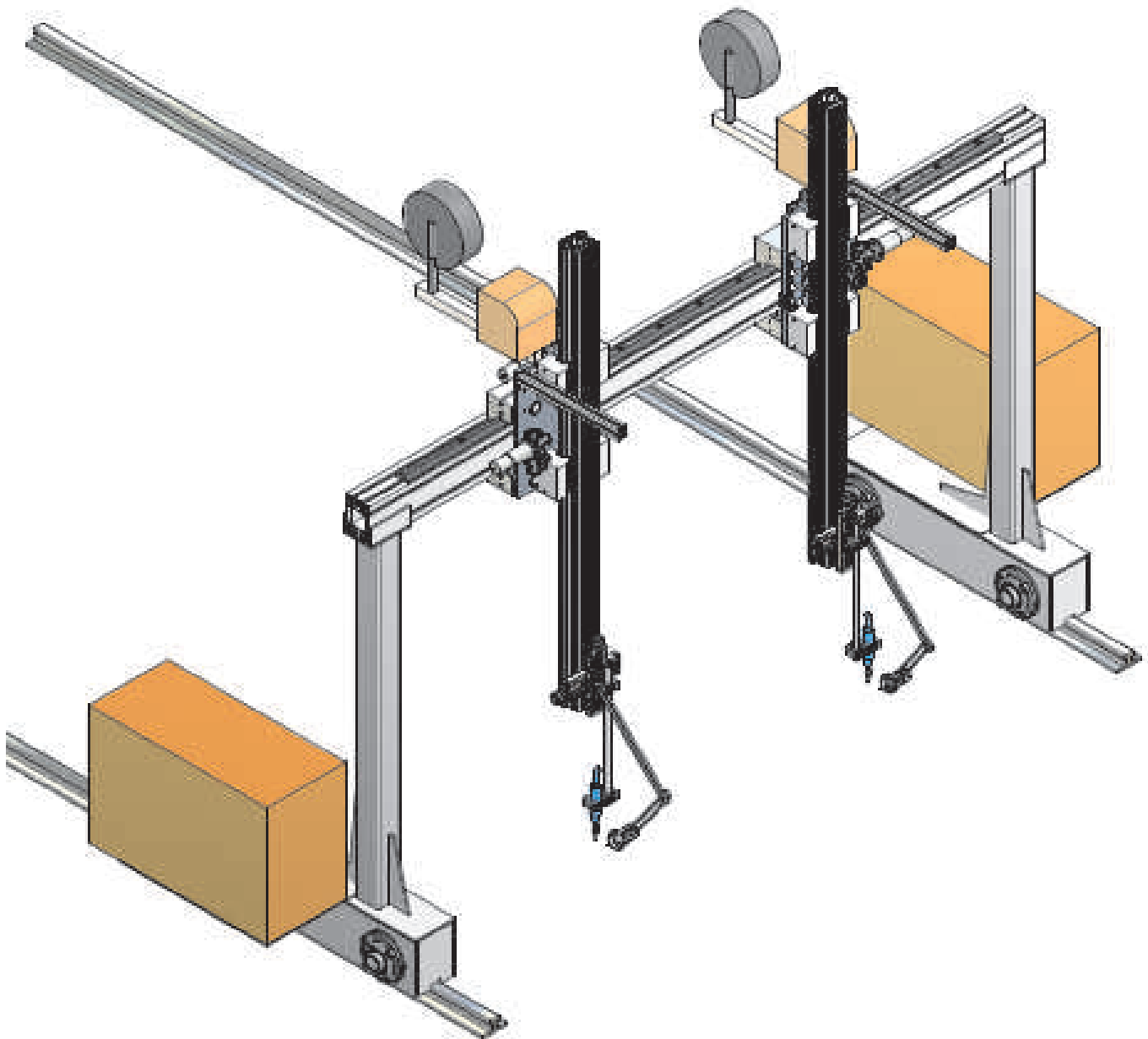

Motorized gantry with 2 seam tracker head

the horizontal axis of each head is the carriage sliding on the beam, and the vertical is an aluminium beam 100x100 mm, with a useful stroke of 1500 mm

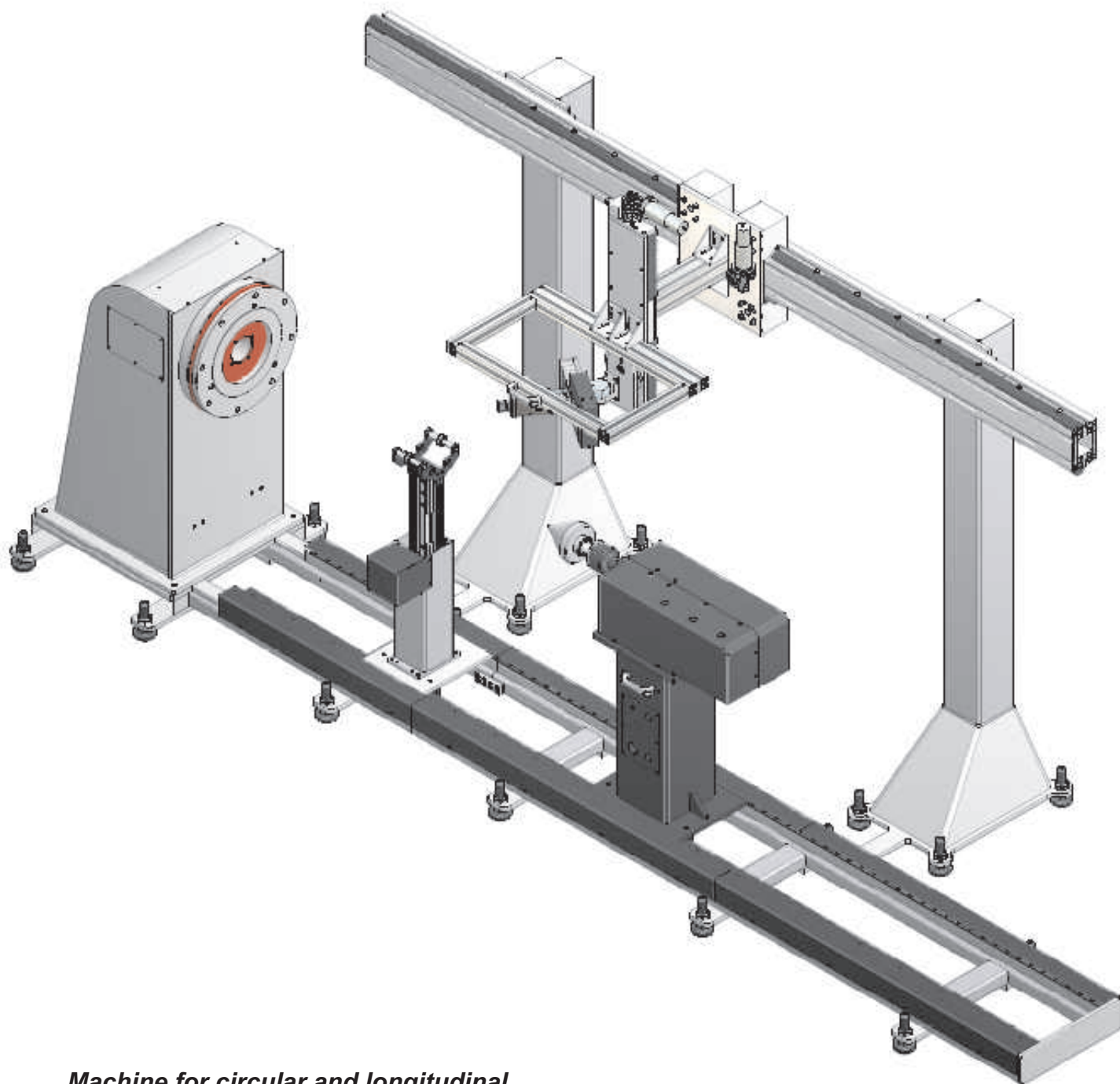

***Machine for circular and longitudinal welding,
complete of pneumatic tail stock and lifting
support for the workpiece***



CARPANO
EQUIPMENT

WELDING AUTOMATION

CARPANO EQUIPMENT Srl
via Cà dell'Orbo 34/7
40055 Castenaso fraz.Villanova
Bologna - Italy
tel. +39 051 6053215 - fax +39 051 6053218
mail@carpanoequipment.com
www.carpanoequipment.com